

XR5FC/XR5SL Commercial Fire Panels Installation Guide

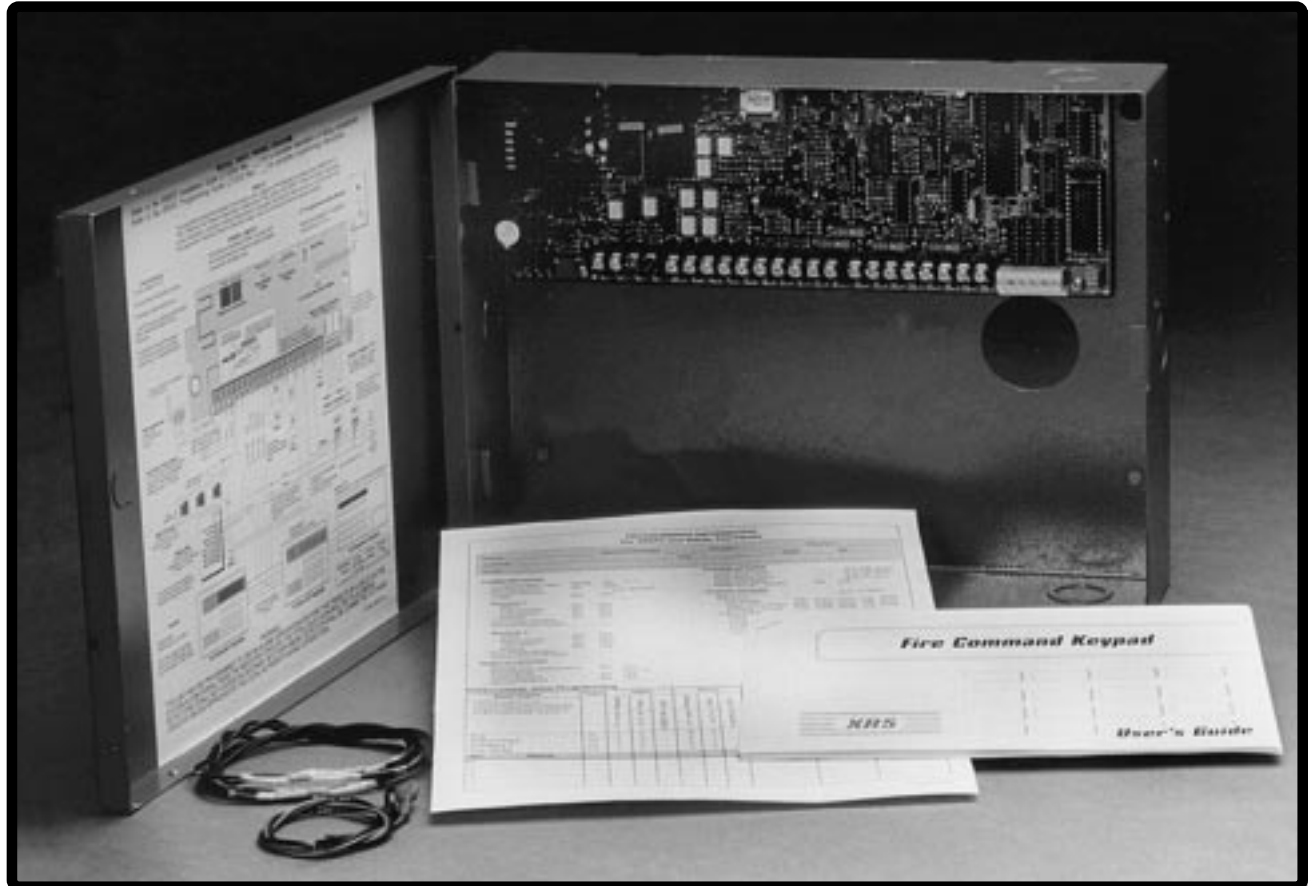

5 Zone Fire and Slave Panels with Built-in Communicators



Digital Monitoring Products

2841 E. Industrial Drive Springfield, MO 65802-6310 800-641-4282

LT-0299 (7/96)

MODELS XR5FC AND XR5SL COMMERCIAL FIRE PANELS INSTALLATION GUIDE

FCC NOTICE

This equipment generates and uses radio frequency energy and, if not installed and used properly in strict accordance with the manufacturer's instructions, may cause interference with radio and television reception. It has been type tested and found to comply with the limits for a Class B computing device in accordance with the specification in Subpart J of Part 15 of FCC Rules, which are designed to provide reasonable protection against such interference in a residential installation. If this equipment does cause interference to radio or television reception, which can be determined by turning the equipment off and on, the installer is encouraged to try to correct the interference by one or more of the following measures:

- Reorient the receiving antenna

- Relocate the computer with respect to the receiver

- Move the computer away from the receiver

- Plug the compute into a different outlet so that computer and receiver are on different branch circuits

If necessary, the installer should consult the dealer or an experienced radio/television technician for additional suggestions. The installer may find the following booklet, prepared by the Federal Communications Commission, helpful:

"How to identify and Resolve Radio-TV Interference Problems."

This booklet is available from the U.S. Government Printing Office, Washington D.C. 20402

Stock No. 004-000-00345-4

Copyright © 1996 Digital Monitoring Products, Inc.

Information furnished by DMP is believed to be accurate and reliable.

This information is subject to change without notice.

TABLE OF CONTENTS

| Section | Page |
|---|------|
| Panel Specifications | |
| 1.1 Power supply | 1 |
| 1.2 Communication | 1 |
| 1.3 Panel zones | 1 |
| 1.4 Remote Annunciators (Alphanumeric or LED Keypads) | 1 |
| 1.5 Auxiliary Outputs | 1 |
| 1.6 Push button reset | 1 |
| 1.7 Enclosure specifications | 1 |
| Introduction | |
| 2.1 Description | 1 |
| 2.2 Before you begin | 2 |
| 2.3 About this guide | 2 |
| 2.4 How to use this guide | 2 |
| System Components | |
| 3.1 Description | 3 |
| 3.2 XR5FC Wiring diagram | 3 |
| 3.3 XR5SL Wiring diagram | 4 |
| 3.4 Lightning protection | 4 |
| 3.5 Security Command® keypads | 4 |
| Installation | |
| 4.1 Mounting the enclosure | 5 |
| 4.2 Model 377 Trouble Annunciator Module | 5 |
| 4.3 Mounting keypads | 6 |
| 4.4 Wiring keypads | 6 |
| Primary Power Supply | |
| 5.1 Terminals 1 and 2 | 6 |
| Secondary Power Supply | |
| 6.1 Battery terminals 3 and 4 | 7 |
| 6.2 Earth ground | 7 |
| 6.3 Replacement period | 7 |
| 6.4 Discharge/recharge | 7 |
| 6.5 Battery supervision | 7 |
| 6.6 XR5FC and XR5SL power requirements | 8 |
| Bell Output | |
| 7.1 Terminal 5 (XR5FC Only) | 8 |
| 4-Wire Smoke Detector Power | |
| 8.1 Terminal 6 (XR5FC Only) | 8 |
| Keypad Data Bus | |
| 9.1 Description | 9 |
| 9.2 Terminal 7 - RED | 9 |
| 9.3 Terminal 8 - YELLOW | 9 |
| 9.4 Terminal 9 - GREEN | 9 |
| 9.5 Terminal 10 - BLACK | 9 |
| Class A (Style D) Fire Zone | |
| 10.1 Description | 9 |

TABLE OF CONTENTS

| Section | Page |
|---|------|
| Class B (Style A) Fire Zones | |
| 11.1 Description | 9 |
| 11.2 Operational parameters | 9 |
| 11.3 Zone response time | 10 |
| 11.4 Compatible 2-wire smoke detectors | 10 |
| Form C Relay Outputs | |
| 12.1 Description | 10 |
| Annunciator Outputs | |
| 13.1 Description | 10 |
| 13.2 Harness wiring | 10 |
| Telephone RJ Connector | |
| 14.1 Description | 11 |
| 14.2 FCC registration | 11 |
| 14.3 Notification | 11 |
| Reset Jumpers | |
| 15.1 Description | 11 |
| Silence/Reset button | |
| 16.1 Silence/Reset button | 11 |
| Dual Phone Line Connectors | |
| 17.1 Description | 11 |
| Universal UL and NFPA Fire Alarm Specifications | |
| 18.1 Introduction | 12 |
| 18.2 Wiring | 12 |
| 18.3 Police station phone number | 12 |
| 18.4 System maintenance | 12 |
| 18.5 Audible alarm (XR5FC only) | 12 |
| 18.6 UL Listed Receivers | 12 |
| UL 864 NFPA 72 Specifications | |
| 19.1 Power Fail delay | 12 |
| 19.2 Central Station Signaling Systems | 12 |
| 19.3 Local Protective Signaling Systems | 12 |
| 19.4 Remote Station Protective Signaling Systems | 12 |
| California State Fire Marshal Specifications | |
| 20.1 Bell output definition | 12 |
| 21.1 Multiple 866 Notification Circuit Modules | 13 |
| 21.2 Multiple 865 Notification Circuit Modules | 14 |
| 21.3 Multiple 866 Notification Circuit Modules for zoned annunciation | 15 |
| 21.4 Remote Station reversing relay connection | 16 |
| 21.5 Supervised remote relay | 17 |
| 21.6 XR5SL Connection to FACP | 18 |

Panel Specifications

1.1 Power supply

Primary Power Input: 16.5 VAC 40VA (Model 320 wire-in) or 12/24 VDC from Fire Alarm Control Panel (FACP)
 Standby Batteries: One or two 12 VDC 7.0Ah
 Auxiliary Output: 500mA at 12 VDC
 Bell Output: 1.5 Amps at 12 VDC (XR5FC only)
 Smoke Detector Output: 100mA at 12 VDC (XR5FC only)
 All circuits inherent power limited except the red battery wire.

1.2 Communication

Built-in SDLC Digital Dialer communication to DMP Model SCS-1 Receivers.
 Built-in 4-2 communication to non-DMP receivers.
 Can operate as a local system (XR5FC only).

1.3 Panel zones

One Class A (Style D) zone (terminals 11 to 14).
 Four 3.3K Ω EOL Class B (Style A) powered fire zones with reset capability (terminals 15 to 22).

1.4 Remote Annunciators (Alphanumeric or LED Keypads)

You can connect alpha Security Command keypads and LED keypads to the XR5FC and XR5SL keypad data bus. The panels do not support zone expansion on the bus.

1.5 Auxiliary Outputs

Two Form C (SPDT) outputs (Outputs 1 and 2). Each output requires one Model 305 plug-in relay. Each relay is rated for 1 Amp at 30 VDC.

Four open collector annunciator outputs (Outputs 1 to 4). No relay is required. Each output is rated for 50mA at 30 VDC resistive.

1.6 Push button reset

The XR5FC and XR5SL panels each provide a push button mounted on the printed circuit board that allows authorized users to reset latch detectors and silence active alarm bell outputs. See section 16.1.

1.7 Enclosure specifications

The XR5 panels are shipped in an enclosure with end of line resistors, battery leads, user's guide, and programming sheet.

| | XR5FC | | XR5SL |
|---------------|-----------------------------------|---------------|-----------------------------------|
| Size: | 12.5" W x 9.5" H x 3.75" D | Size: | 12.5" W x 9.5" H x 2.75" D |
| Weight: | 4 lbs | Weight: | 4 lbs |
| Color: | Red | Color: | Red |
| Construction: | 20 gauge cold rolled steel | Construction: | 20 gauge cold rolled steel |

Introduction

2.1 Description

The DMP XR5FC and XR5SL Commercial Fire Panels are powerful 12 VDC fire alarm communicators with battery backup that can also be powered from the 12 or 24 VDC auxiliary output of a Fire Alarm Control Panel (FACP). Each panel provides one Class A (Style D) fire zone and four Class B (Style A) powered fire zones with reset capability for 2-wire smoke detectors, relays, or other latching devices.

The XR5 panels can communicate to one or two DMP SCS-1 Receivers using SDLC digital dialer or to one or two non-DMP receivers using the 4-2 reporting format.

2.2 Before you begin

Before installing the XR5, we recommend you read through the entire contents of this guide. Familiarize yourself with the features of the panel and the key points to remember during the installation. Be sure to read and understand all of the caution statements printed in bold italics.

In addition to this installation guide, you should also read through and familiarize yourself with these other product documents:

- XR5 Programming Guide (I.T-0312)
- XR5 User's Guide (LT-0296)
- XR5 Program Information Sheet (LT-0297)

2.3 About this guide

The information contained in this guide is organized into three sections: Table of Contents, Introduction, and Installation.

- The Table of Contents at the front of this guide lists all of the headings and subheadings used throughout each section. To the right of each heading is the section number where the information can be found.
- The Introduction section gives you an overview of the various components that go into an XR5 system and diagrams some typical system configurations. This section gives descriptions of the panel, keypads, and accessory modules and provides details on how each of them operate together in the system.
- The Installation section begins with mounting instructions for the enclosure and takes you through the proper way to power up the panel prior to programming.

Caution notes

Throughout this guide you'll see caution notes containing information you need to know when installing the XR5 panels. These cautions are written in bold italics and are followed by a detailed description of the caution. See the example shown below:

Always ground the panel before applying power to any devices: The XR5 panels must be properly grounded before connecting any devices or applying power to the panel. Proper grounding protects against Electrostatic Discharge (ESD) that can damage system components.

Whenever you see a caution note, make sure you completely read and understand its information. Failing to follow the caution note can cause damage to the equipment or improper operation of one or more components in the system.

2.4 How to use this guide

To locate information about installing the XR5 panels, first go to the Table of Contents at the front of this guide. Find the subject heading that closely describes the information you need and turn to the section number shown to the right of the heading.

The text that follows the heading has been written to provide as much information about the subject as possible. If you can't find the information you need under that heading, try scanning through a few of the headings before and after and reading the text under those that sound similar.

System Components

3.1 Description

A basic XR5 system is made up of the alarm panel with built in communicator, an enclosure, a 16.5 VAC wire-in transformer, and a 12 VDC 7.0Ah battery. You can add up to two alphanumeric Security Command keypads and one LED Security Command keypad to the panel and also connect control and annunciating devices to the panel's Form C and annunciator outputs. Refer to section 6.6 in this guide when calculating power requirements.

3.2 XR5FC Wiring diagram

The XR5FC system below shows some of the accessory devices you can connect for use in various applications.

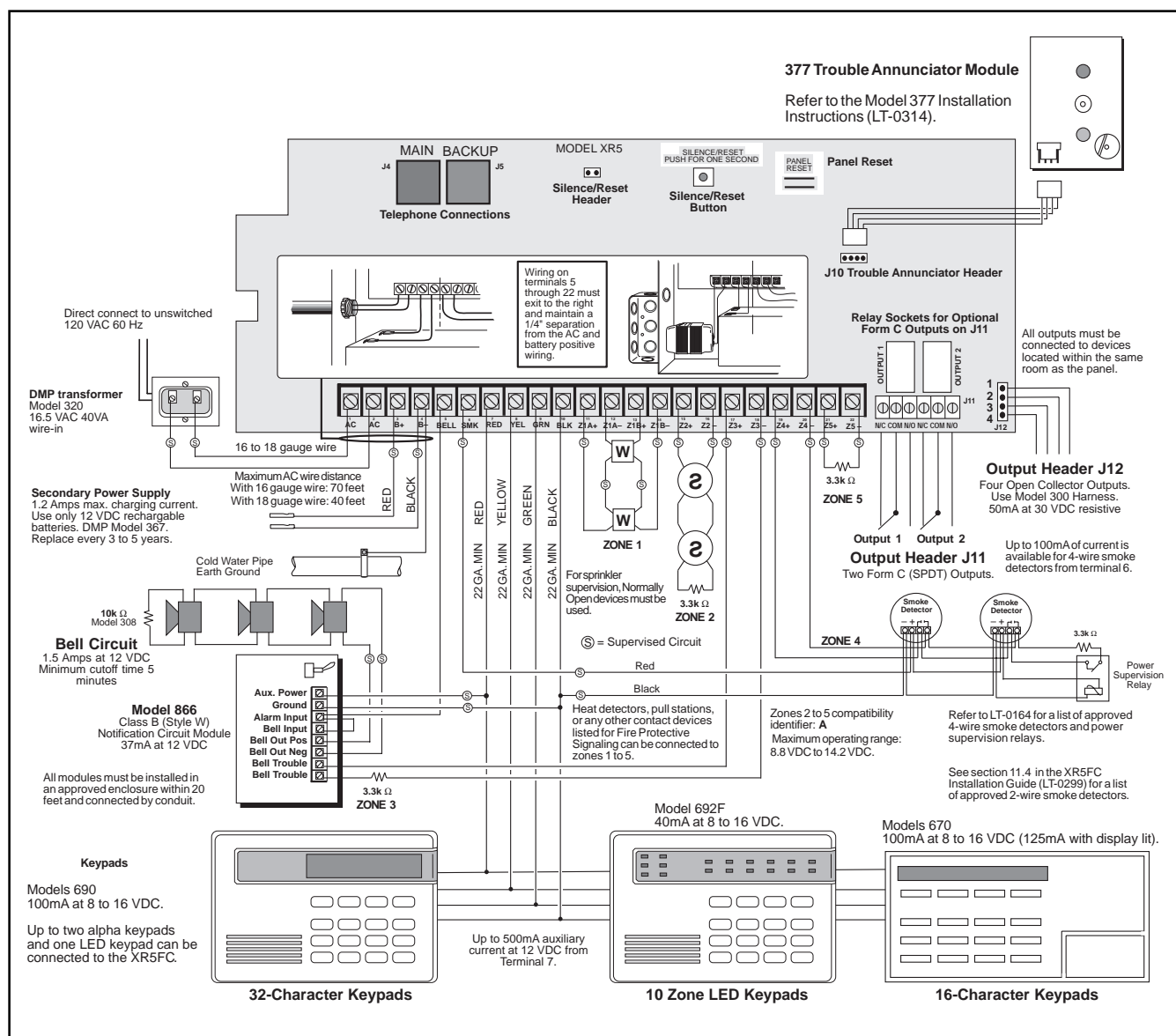

Figure 1: XR5FC wiring diagram

3.3 XR5SL Wiring diagram

The XR5SL system below shows some of the accessory devices you can connect for use in various applications.

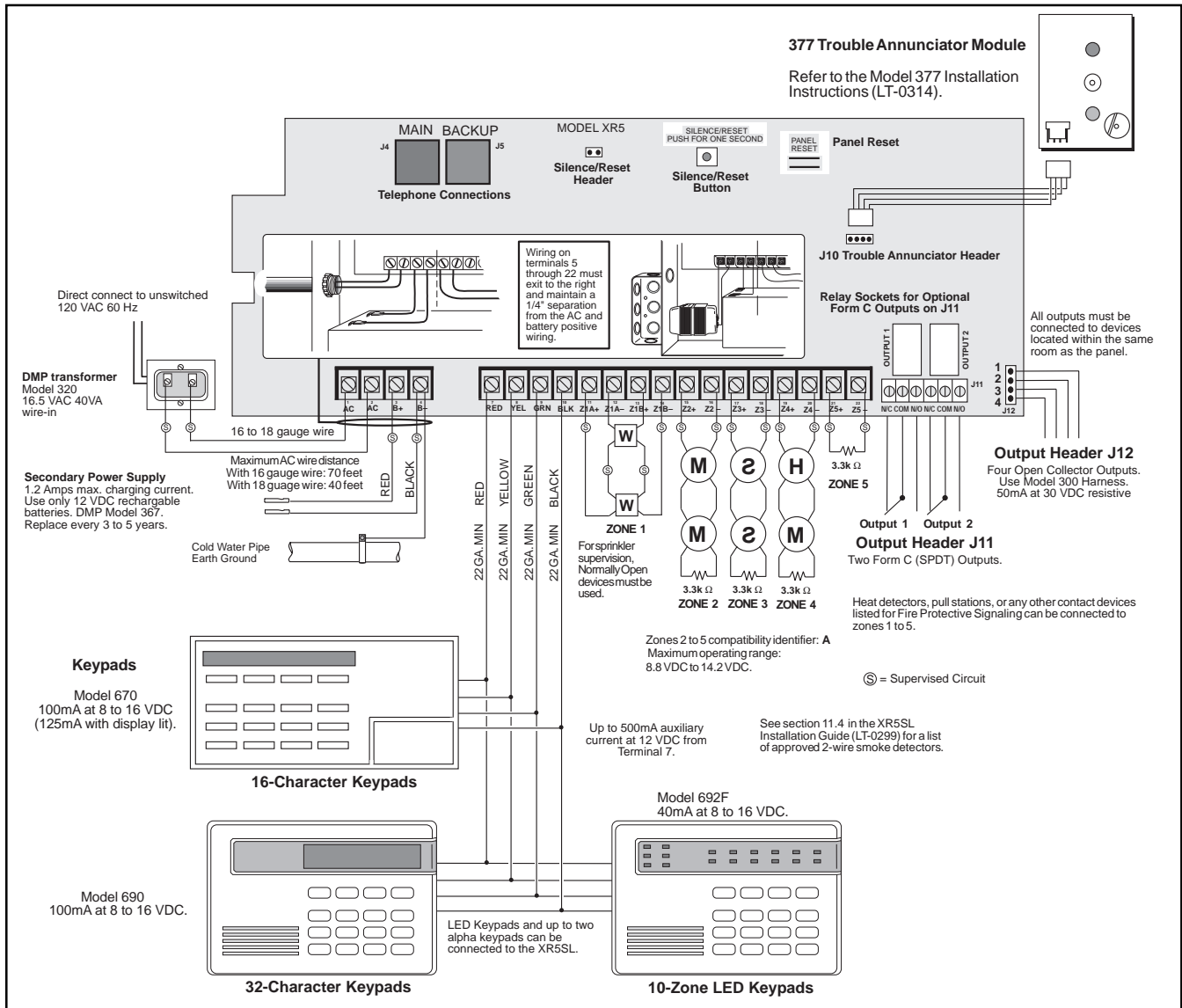

Figure 2: XR5SL wiring diagram

3.4 Lightning protection

Metal Oxide Varistors and Transient Voltage Suppressors on the panel help protect against voltage surges on input and output circuits of the XR5 panels. Additional surge protection is available by installing the DMP 370 or 370RJ Lightning Suppressors.

3.5 Security Command® keypads

You can connect the Models 670, 690, 692F, 770, 771, or 790 Security Command keypads to the 4-wire keypad data bus provided by the panel on terminals 7, 8, 9, and 10.

Installation

4.1 Mounting the enclosure

The metal enclosure for the XR5FC and XR5SL panels must be mounted in a secure, dry place to protect the panels from damage due to tampering or the elements. It is not necessary to remove the XR5FC or XR5SL PC board when installing the enclosure.

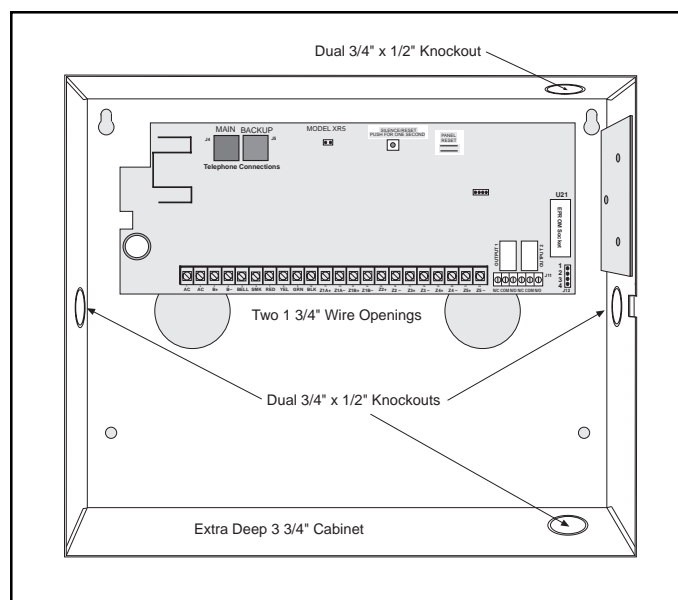

Figure 3A: XR5FC in standard Model 340FC enclosure.

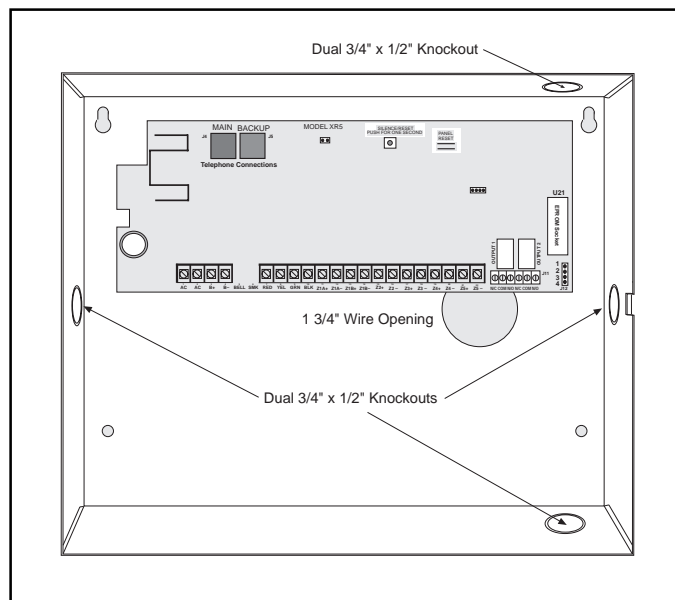

Figure 3B: XR5SL in standard Model 340SL enclosure.

4.2 Model 377 Trouble Annunciator Module

The 377 module is installed on the enclosure door and connects to the panel through a 4-wire harness supplied with the module. See Figure 4.

377 module operation

The 377 Trouble Annunciator Module provides visual and audible annunciation of System Okay, communication trouble, and panel processor failure. The module contains a Green LED for System Okay, a Yellow LED for Trouble, an electronic sounder, and a Silence switch.

System Okay

When both phone lines are normal and the panel processor is operating, only the Green LED on the 377 module is on. This LED goes off during a Sensor Reset.

Communication trouble

If either phone line connected to the panel is in a bad condition, or if the panel has made TEN failed attempts to send a report to the central station receiver, the 377 module emits a steady audible alert and turns on the Yellow LED. The Silence switch can be used to turn off the sounder only.

Panel processor failure

During a processor failure on the panel, or a remote programming session, the 377 module emits a steady audible alert and turns on the Yellow LED. **The Silence switch will not turn off the sounder or Yellow LED during these conditions.**

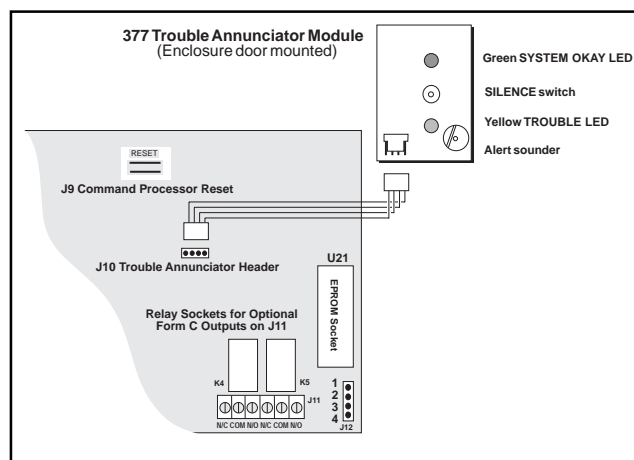

Figure 4: 377 module wire harness

4.3 Mounting keypads

Security Command keypads have removable covers that allow you to easily mount the base to a wall or other flat surface. After installing the keypad mounting anchors and bringing the keypad wiring from the panel through the wall, mount the base and connect the keypad wire harness leads to the keypad wiring. Next, attach the keypad wire harness connector to the pin connector on the keypad circuit board and install the cover.

For mounting keypads on masonry walls, or for applications where conduit is required, use an appropriate DMP keypad conduit backbox.

4.4 Wiring keypads

Keypad data bus

The keypad data bus consists of a 4-wire cable that provides 12 VDC power, data in, data out, and a panel common. You can connect keypads in parallel on one 4-wire cable or provide a separate cable run back to the panel for each keypad. The maximum cable length for one keypad can be up to 500 feet using 22 gauge wire or up to 1000 feet using 18 gauge wire.

Refer to the wiring diagram in this guide for additional wiring information. See section 3.2.

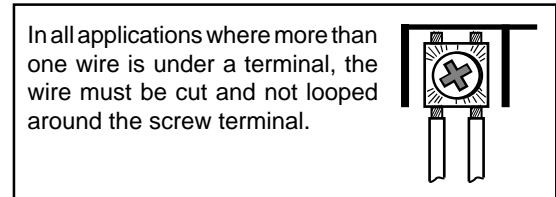

Figure 5: Proper wiring connections

Primary Power Supply

5.1 Terminals 1 and 2

AC transformer input

Connect the wires from the Model 320, 16.5 VAC 40VA transformer to terminals 1 and 2 on the panel. Use no more than 70 ft. of 16 gauge or 40 ft. of 18 gauge wire between the transformer and the XR5FC or XR5SL panel.

The transformer provides up to 500mA of auxiliary current for the XR5FC and XR5SL panels. The total current available is limited by the total battery standby requirements of the installation. See section 6.6 for standby battery calculations.

The transformer requires an unswitched 120 VAC 60 Hz electrical outlet with at least 350mA of available current. **Never share the transformer output with any other equipment.** The 120 VAC circuit is not power limited.

DC power input to AC input

When powering the XR5FC/SL panel from the 12 VDC output of a FACP, connect the positive wire to the positive battery terminal of the XR5 and the negative wire to the negative battery terminal of the XR5.

When powering the panel from the DC output of a 24 Volt Fire Alarm Control Panel (FACP), connect the **positive** wire from the FACP to terminal **1** and the **negative** wire to terminal **2**.

Do not use battery backup with 12 or 24 VDC input: Do not connect *any* batteries to the XR5FC or XR5SL panels when using the 12 or 24 VDC output from a FACP. The XR5FC and XR5SL panels use the backup battery capability of the FACP for their standby requirements.

Features disabled when using 24 VDC power input: When powering the XR5FC or XR5SL panel from the 24 VDC output of a FACP, the following operational features are disabled:

- Bell Output on the XR5FC
- AC test (XR5FC and XR5SL)
- Battery test (XR5FC and XR5SL)

Always ground the panel before applying power to any devices: The XR5FC and XR5SL panels must be properly grounded before connecting any devices or applying power to the panels. Proper grounding protects against Electrostatic Discharge (ESD) that can damage system components. See Earth ground, section 6.2.

Secondary Power Supply

6.1 Battery terminals 3 and 4

Connect the black battery lead to terminal 4 on the panel and then to the negative terminal of the battery. The negative terminal connects to the enclosure ground internally through the XR5FC and XR5SL panel circuit board. Connect the red battery lead to terminal 3 on the panel and then to the positive terminal of the battery. **Observe polarity when connecting the battery.**

The XR5FC and XR5SL panels are capable of recharging two 7.0Ah batteries (14 Amp/hours) within 24 hours.

Do not use battery backup with 24 VDC input: Do not connect batteries to the XR5FC and XR5SL panels when powering the panels with 20 to 28.2 VDC voltage from a Fire Alarm Control Panel (FACP). The XR5FC and XR5SL panels use the backup battery capability of the FACP for their standby requirements.

Use sealed lead-acid batteries only: Use the DMP Model 367, 12 VDC 7.0Ah sealed lead-acid rechargeable battery. Batteries supplied by DMP or manufactured by Eagle Picher or Yuasa have been tested to ensure proper charging with DMP products.

GEL CELL BATTERIES CANNOT BE USED WITH THE XR5FC AND XR5SL.

6.2 Earth ground

Terminal 4 of the XR5FC and XR5SL panels must be connected to earth ground using 14 gauge or larger wire to provide proper transient suppression. DMP recommends connecting to a metal cold water pipe or ground rod only. Do not connect to electrical conduit or a telephone company ground.

6.3 Replacement period

DMP recommends the battery be replaced every 3 to 5 years under normal use.

6.4 Discharge/recharge

The battery charging circuit on the XR5FC and XR5SL panels float charge at 13.9 VDC at a maximum current of 1.2 Amps using the Model 320 Transformer. The total current available is reduced by the combined auxiliary current draw from terminals 6, 7, 15, 17, 19, and 21. The various battery voltage levels are listed below:

| | |
|-------------------|----------------|
| Battery Trouble: | Below 11.9 VDC |
| Battery Restored: | Above 12.6 VDC |

6.5 Battery supervision

The XR5FC and XR5SL panels test the battery once every hour when AC power is present on terminal 1 and 2. The test lasts for five seconds and consists of the panels putting a load on the battery. If, during the test, the battery voltage falls below 11.9 VDC a low battery is indicated. The test is then repeated every two minutes until the battery charges above 12.6 VDC, the battery restored voltage.

If the low battery does not recharge and is replaced with a fully charged battery, the charged battery will not be detected until the next two minute test is done.

If AC power fails during normal system operation, a low battery is indicated **any time** the battery voltage falls below 11.9 VDC.

6.6 XR5FC and XR5SL power requirements

During AC power failure, the XR5FC and XR5SL panels, and all auxiliary devices connected to the panels, draw their power from the battery. All devices must be taken into consideration when calculating the battery standby capacity. Below is a list of the power requirements of the XR5FC and XR5SL panels. Add the additional current draw of Security Command keypads, smoke detectors, and any other auxiliary devices used in the system for the total current required.

XR5FC and XR5SL STANDBY BATTERY POWER CALCULATIONS

| | Standby Current | Alarm Current |
|--|----------------------------|----------------------------|
| XR5FC/XR5SL Panels | 50mA _____ mA | 50mA _____ mA |
| Relay Outputs 1 and 2 (ON) | Qty _____ x 30mA _____ mA | Qty _____ x 30mA _____ mA |
| Active Zone 1 | Qty _____ x 3.3mA _____ mA | Qty _____ x 3.3mA _____ mA |
| Active Zones 2 to 5 | Qty _____ x 4mA _____ mA | 30mA _____ mA |
| 2-Wire Smokes | Qty _____ x .1mA _____ mA | Qty _____ x .1mA _____ mA |
| Bell Output (XR5F only) | | 1500mA max. _____ mA |
| 670, 770, and 771 Keypads | Qty _____ x 125mA _____ mA | Qty _____ x 125mA _____ mA |
| Annunciator (On) | | Qty _____ x 20mA _____ mA |
| 690 & 790 Keypads (annunciator on or off) | Qty _____ x 100mA _____ mA | Qty _____ x 100mA _____ mA |
| 692F Keypad | Qty _____ x 30mA _____ mA | Qty _____ x 30mA _____ mA |
| Annunciator (On) | | Qty _____ x 10mA _____ mA |
| Auxiliary Powered Devices on Terminals 7 and 11 (Other than keypads) | _____ mA | _____ mA |
| | Total Standby _____ mA | Total Alarm _____ mA |

* Based on 10% of active zones in alarm condition

Total Standby _____ mA x number of standby hours needed _____ = _____ mA/hours

Total Alarm + _____ mA/hours

Total _____ mA/hours

x .001 _____

= _____ A/hours required

Bell Output

7.1 Terminal 5 (XR5FC Only)

Terminal 5 supplies 12 VDC Bell Output to power alarm bells or horns. The output is rated for a maximum of 1.5 Amps. This output can be steady or pulsed depending upon the Bell Action specified in Output Options programming. Terminal 10 is the ground reference for terminal 5.

4-Wire Smoke Detector Power

8.1 Terminal 6 (XR5FC Only)

Terminal 6 provides up to 100mA at 12 VDC to power 4-wire smoke detectors or other auxiliary powered devices. This output can be turned off by the user for 5 seconds using the Sensor Reset User Menu option. Terminal 10 is the ground reference for terminal 6.

Keypad Data Bus

9.1 Description

Terminals 7, 8, 9, and 10 of the XR5FC and XR5SL panels provide the keypad data bus to which you can connect Model 692F LED keypads as well as two alphanumeric Security Command keypads.

9.2 Terminal 7 - RED

Terminal 7 provides 12 VDC keypad power for Security Command keypads. You can also connect 12 VDC auxiliary devices to terminal 7. The ground reference for terminal 7 is terminal 10. The maximum output is rated at 500mA on the XR5FC and XR5SL panels. All auxiliary devices totalled together must not exceed the panel's maximum current rating.

9.3 Terminal 8 - YELLOW

Data receive from keypads.

9.4 Terminal 9 - GREEN

Data transmit to keypads.

9.5 Terminal 10 - BLACK

Terminal 10 is the ground reference for keypads and any auxiliary devices being powered by terminal 7.

Class A (Style D) Fire Zone

10.1 Description

Terminals 11 to 14 are the panel's Class A (Style D) fire zone. This zone is suitable for connecting waterflow devices, heat detectors, and other non-powered fire devices. For programming purposes, this is zone number 1. The zone is rated for 1.66mA at 5.0 VDC.

The zone configuration on terminals 11 to 14 are described below.

| Terminal | Function | Terminal | Function |
|----------|------------------------|----------|--------------------------|
| 11 | Zone 1 voltage sensing | 12 | Negative for terminal 11 |
| 13 | Zone 1 voltage sensing | 14 | Negative for terminal 13 |

The voltage sensing terminal measures the voltage flowing through the circuit to the zone's negative terminal. Dry contact sensing devices can be used only in parallel (normally-open) with zone 1. There are no End of Line resistors on a Class A (Style D) zone.

Class B (Style A) Fire Zones

11.1 Description

Terminals 15 to 22 are the Class B (Style A) fire zones on the XR5FC and XR5SL panels. These zones are suitable for connecting powered or non-powered fire devices. For programming purposes, these zones are designated 2 to 5. The zone configurations on terminals 15 to 22 are described below:

| Terminal | Function | Terminal | Function |
|----------|------------------------|----------|-----------------|
| 15 | Zone 2 voltage sensing | 16 | Zone 2 negative |
| 17 | Zone 3 voltage sensing | 18 | Zone 3 negative |
| 19 | Zone 4 voltage sensing | 20 | Zone 4 negative |
| 21 | Zone 5 voltage sensing | 22 | Zone 5 negative |

11.2 Operational parameters

The Class B (Style A) zones on the XR5FC and XR5SL panels can detect three conditions: open, normal, and short. Each zone terminates with a Model 309, 3.3k Ω EOL resistor (provided with the panel) and is rated for 53mA at 12 VDC.

The UL compatibility identifier for use with 2-wire smoke detectors is: **A**.

11.3 Zone response time

A condition must be present on the zone for at least 500 milliseconds before it is detected by the XR5FC and XR5SL panels. Ensure detection devices used on the zones are rated for use with this delay.

11.4 Compatible 2-wire smoke detectors

The table to the right lists those detectors meeting the compatibility requirements for use with the Class B (Style A) zones on the XR5FC and XR5SL fire panels.

Do not mix detectors from different manufacturers on the same zone.

| Make | Model | Detector ID | Base | Base ID | # of Detectors |
|-------------------|----------|-------------|---------------------|---------|----------------|
| Detection Systems | DS282 | B | None | N/A | 10 |
| Detection Systems | DS282TH | B | None | N/A | 10 |
| Detection Systems | DS250 | B | MB2W, MB2WL | A | 10 |
| Detection Systems | DS250TH | B | MB2W, MB2WL | A | 10 |
| Detection Systems | DS250HD | B | MB2W, MB2WL | A | 10 |
| Sentrol/ESL | 429AT | S09A | None | N/A | 12 |
| Hochiki | SLK-835 | HD-5 | HSB-200, HSB-200N | HB-55 | 7 |
| Hochiki | SLK-835H | HD-5 | HSB-200, HSB-200N | HB-55 | 7 |
| Hochiki | SLK-12 | HD-4 | HSB-12-1, HSB-12-1N | HB80 | 20 |

Figure 6: Compatible 2-wire smoke detectors

Form C Relay Outputs

12.1 Description

The XR5FC and XR5SL panels can provide two auxiliary Form C (SPDT) relays when equipped with DMP Model 305 Plug-in Relays in sockets OUTPUT 1 and OUTPUT 2. Each relay is rated for 1 Amp at 30 VDC.

Each output provides one Common, one Normally Open, and one Normally Closed terminal. Field wiring for the Form C relays connects to the 6-position terminal strip on the lower right corner of the XR5FC and XR5SL boards.

The Form C relays can be operated by any of the functions listed below:

- 1) Activation by a zone condition
- 2) Communication Failure
- 3) Fire alarm or Fire trouble

Annunciator Outputs

13.1 Description

The XR5FC and XR5SL panels provide four open collector annunciator outputs that can be programmed to indicate the activity of the panel's zones or conditions occurring on the system. **Open collector outputs do not provide a voltage but instead switch to ground voltage from another source. Each annunciator output is rated for 50mA at 30 VDC resistive.**

Form C and Annunciator outputs operate together: The Form C outputs 1 and 2 are internally connected to the Annunciator outputs 1 and 2. Any options assigned to Output 1 or 2 in the panel's Output Options programming applies to both outputs. While the Form C outputs each require a Model 305 Plug-in Relay, the annunciator outputs will work without the relays.

The Annunciator outputs can respond to any of the conditions listed below:

- 1) Activation by zone condition
- 2) Communication failure
- 3) Fire Alarm or Fire Trouble

13.2 Harness wiring

The Annunciator outputs are accessible by installing the DMP 300 Harness on the 4-pin header labeled J12. The output locations are shown below:

| Output | Color | Wire |
|--------|--------|------|
| 1 | Red | 1 |
| 2 | Yellow | 2 |
| 3 | Green | 3 |
| 4 | Black | 4 |

Devices connected to the outputs must be located within the same room as the XR5FC and XR5SL panels.

Telephone RJ Connector

14.1 Description

Connect the panel to the public telephone network by installing DMP 356 RJ Cables between the panel's J4 (MAIN) and J5 (BACKUP) connectors and the RJ31X or RJ38X phone jacks.

14.2 FCC registration

The XR5FC and XR5SL panels comply with FCC part 68 and are registered with the FCC.

Registration number: CCK USA - 18660 - AL - R

Ringer Equivalence: 1.1B

14.3 Notification

Registered terminal equipment must not be repaired by the user. In case of trouble, the device must be immediately unplugged from the telephone jack. The factory warranty provides for repairs. Registered terminal equipment may not be used on party lines or in connection with coin telephones. Notification must be given to the telephone company of:

- a. The particular line(s) the service is connected to
- b. The FCC registration number
- c. The ringer equivalence
- d. The make, model, and serial number of the device

Reset Jumpers J9

15.1 Description

There are two reset jumpers located at the top right of the panel's circuit board labeled RESET. Momentarily shorting these jumpers allows you to reset the microprocessor of the XR5FC and XR5SL panels allowing you to enter the internal Programmer.

You can reset the panel while the system is operational (for example, during a service call) without powering down the system.

After resetting the panel for programming, you must begin within 30 minutes. If you wait longer than 30 minutes, you'll have to reset the panel again.

Silence/Reset button

16.1 Silence/Reset button

The XR5FC and XR5SL panels each contain a mechanical push button located on the top center of the printed circuit board that allows authorized users to silence alarm bells or sirens and reset latched detection devices.

After pressing the button, the panel silences the Bell output (XR5FC terminal 5) and momentarily drops power to the auxiliary output (XR5FC terminal 6), the 377 Trouble Annunciator Module, and zones 2 to 5 (both panels). Additionally, any Fire or Supervisory event displays at the keypads are also cleared. A 2-pin reset header is also provided for use with keyswitches.

Dual Phone Line Connectors

17.1 Description

The XR5FC and XR5SL panels contain built-in dual phone line capability that allows the panel to monitor two phone lines, indicate a phone line failure, and switch to the alternate phone line to communicate alarm and system reports to a central station.

Before sending a report, the panel verifies whether the main phone line is working. If not, the panel sends the report over the backup phone line. An integrated phone line monitor circuit continually tests the phone lines and indicates a trouble condition on the line after 90 seconds. If the phone line restores and is good for 90 seconds, the panel ends the phone line trouble indication.

UNIVERSAL UL and NFPA FIRE ALARM SPECIFICATIONS

18.1 Introduction

The programming and installation specifications contained in this section must be completed when installing the XR5FC and XR5SL panels in accordance with any of the UL or NFPA fire standards. Additional specifications may be required by a particular standard.

18.2 Wiring

All wiring must be in accordance with NEC, ANSI/NFPA 70.

18.3 Police station phone number

The digital dialer telephone number programmed for communication must not be a police station phone number, unless that phone number is specifically provided for that purpose.

18.4 System maintenance

Proper installation and regular maintenance by the installing alarm company and frequent testing by the end user is essential to ensure continuous satisfactory operation of any alarm system. Offering a maintenance program and acquainting the user with the correct procedure for use and testing of the system is also the responsibility of the installing alarm company.

18.5 Audible alarm (XR5FC only)

Fire Type zones should be programmed to activate an audible alarm. The Bell Action for Fire Type zones should not be programmed as "N". See section 6.3A in the XR5FC and XR5SL Programming Guide (LT-0312).

18.6 UL Listed Receivers

UL has verified operation with the Sur-Gard SG-HLR2-DG, FBII CP220PB, Osborne-Hoffman Quick-Alert, and Radionics D6500 receivers.

UL 864 NFPA 72 SPECIFICATIONS

Control Units for Fire Protective Signaling Systems

19.1 Power Fail delay

The Power Fail Delay option must be set to 6 hours. See section 5.4 of the Programming Guide (LT-0312).

19.2 Central Station Signaling Systems

Two phone lines must be used. The two phone lines cannot be ground start or party lines. See section 3.3 of the XR5FC and XR5SL Programming Guide (LT-0312).

Two different phone numbers must be programmed for digital communication. See sections 3.12 and 3.15 of the XR5FC and XR5SL Programming Guide (LT-0312).

19.3 Local Protective Signaling Systems

The DMP Model 865 or 866 Notification Circuit Module must be used on the bell circuit for detection of shorts and grounds. See sections 20.1 to 20.3 of this guide.

19.4 Remote Station Protective Signaling Systems

You must provide 60 hours of standby battery. Up to two 12 VDC, 7.0Ah batteries may be used. See section 6.6 for standby battery calculations. Two Radionics Model D127 Reversing Relay Modules may be used to provide two reversing polarity telephone connections instead of dual phone lines. See section 20.4 and the D127 Installation Instruction sheet for wiring details.

CALIFORNIA STATE FIRE MARSHAL SPECIFICATIONS

20.1 Bell output definition

The bell output of the Model XR5FC must be programmed to operate pulsed on fire alarms. See section 6.3A of the XR5FC and XR5SL Programming Guide (LT-0312).

21.1 Multiple 866 Notification Circuit Modules

To additional eleven 866 Notification Circuit Modules. Up to a maximum of thirteen 866 modules on the XR5 panels. Modules must be installed in a Model 340FC, 340SL, 349, or 350 enclosure connected by no more than 20 feet of conduit.

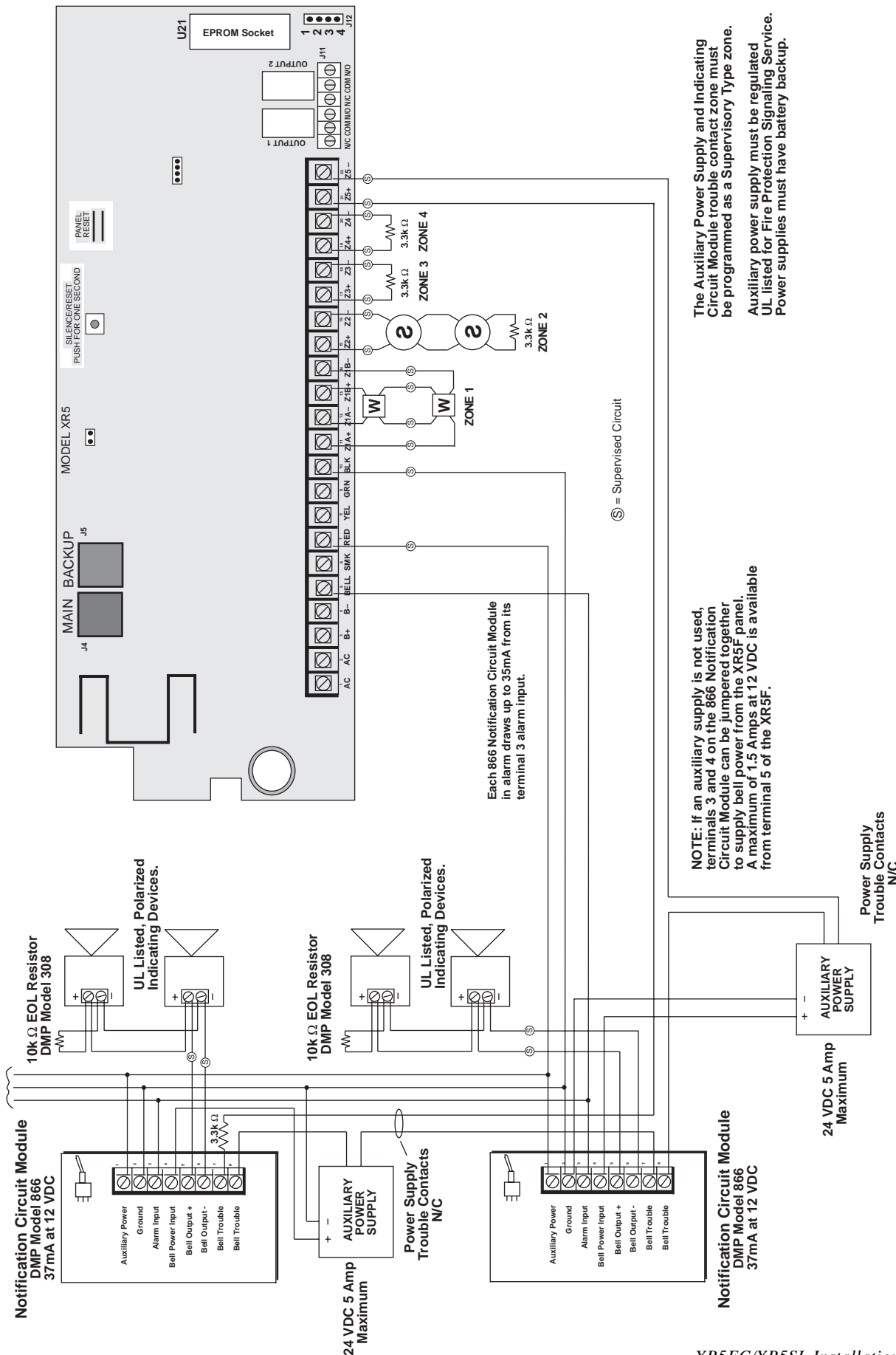

21.2 Multiple 865 Notification Circuit Modules

To additional three 865 Notification Circuit Modules. Up to a maximum of five 865 modules on the XR5 panels. Modules must be installed in a Model 340FC, 340SL, 349, or 350 enclosure connected by no more than 20 feet of conduit.

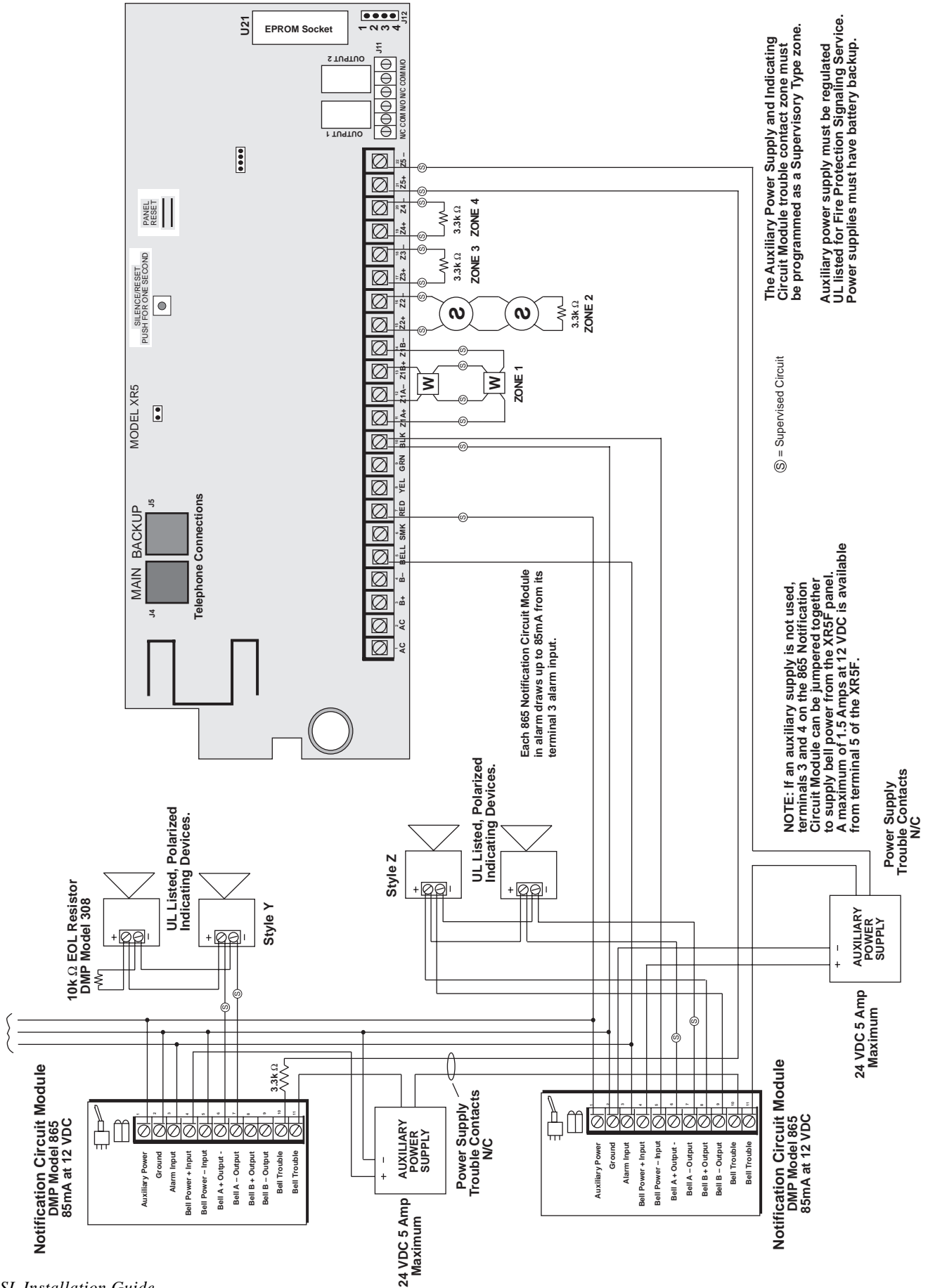

NOTE: If an auxiliary supply is not used, terminals 3 and 4 on the 865 Notification Circuit Module can be jumpered together to supply bell power from the XR5F panel. A maximum of 1.5 Amps at 12 VDC is available from terminal 5 of the XR5F.

The Auxiliary Power Supply and Indicating Circuit Module trouble contact zone must be programmed as a Supervisory Type zone. Auxiliary power supply must be regulated UL listed for Fire Protection Signaling Service. Power supplies must have battery backup.

(S) = Supervised Circuit

24 VDC 5 Amp Maximum
AUXILIARY POWER SUPPLY
Power Supply Trouble Contacts N/C

21.3 Multiple 866 Notification Circuit Modules for zoned annunciation

To additional ten 866 Notification Circuit Modules. Up to a maximum of thirteen 866 modules on the XR5FC panel. Modules must be installed in a Model 340FC, 340SL, 349, or 350 enclosure connected by no more than 20 feet of conduit.

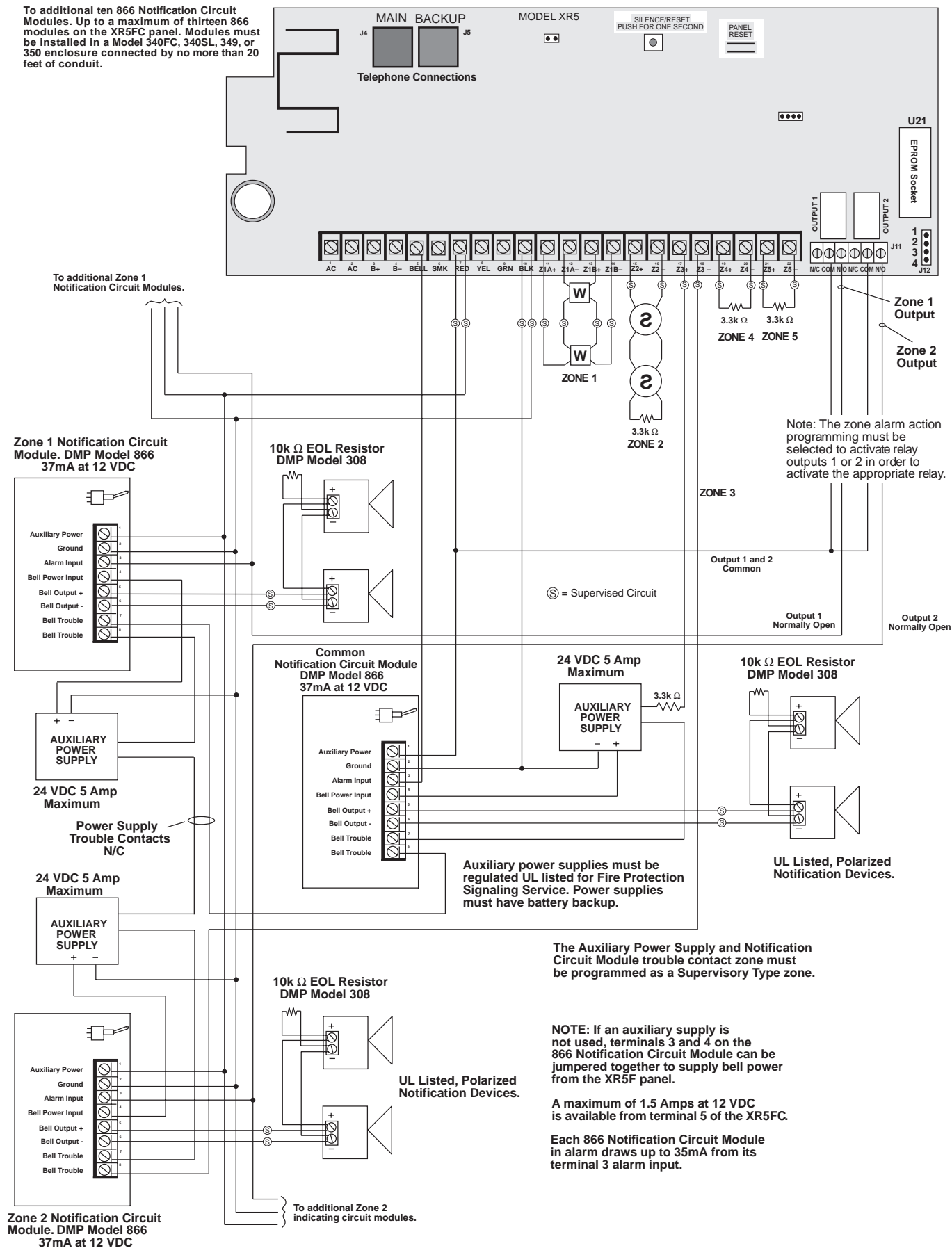

21.4 Remote Station reversing relay connection

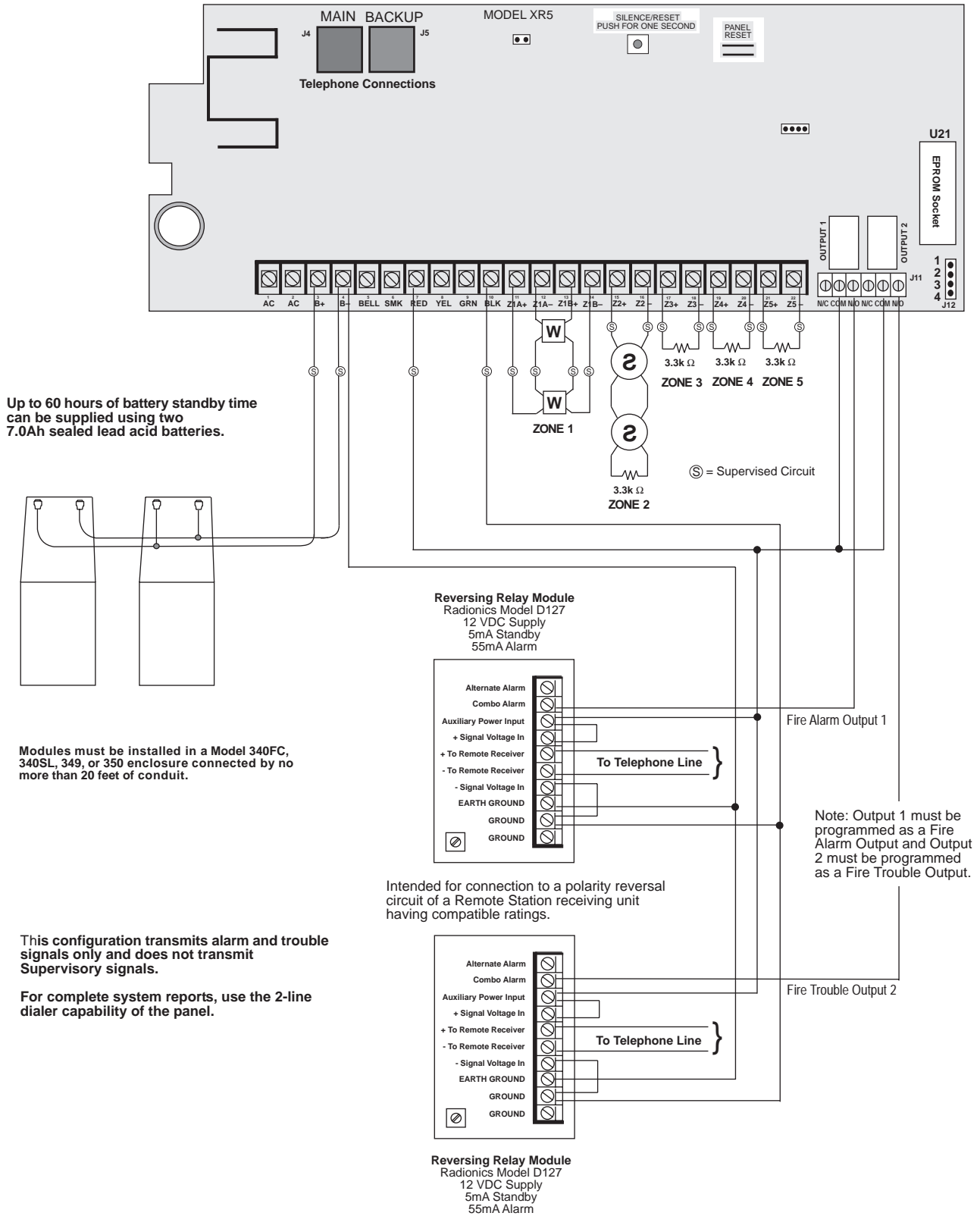

21.5 Supervised remote relay

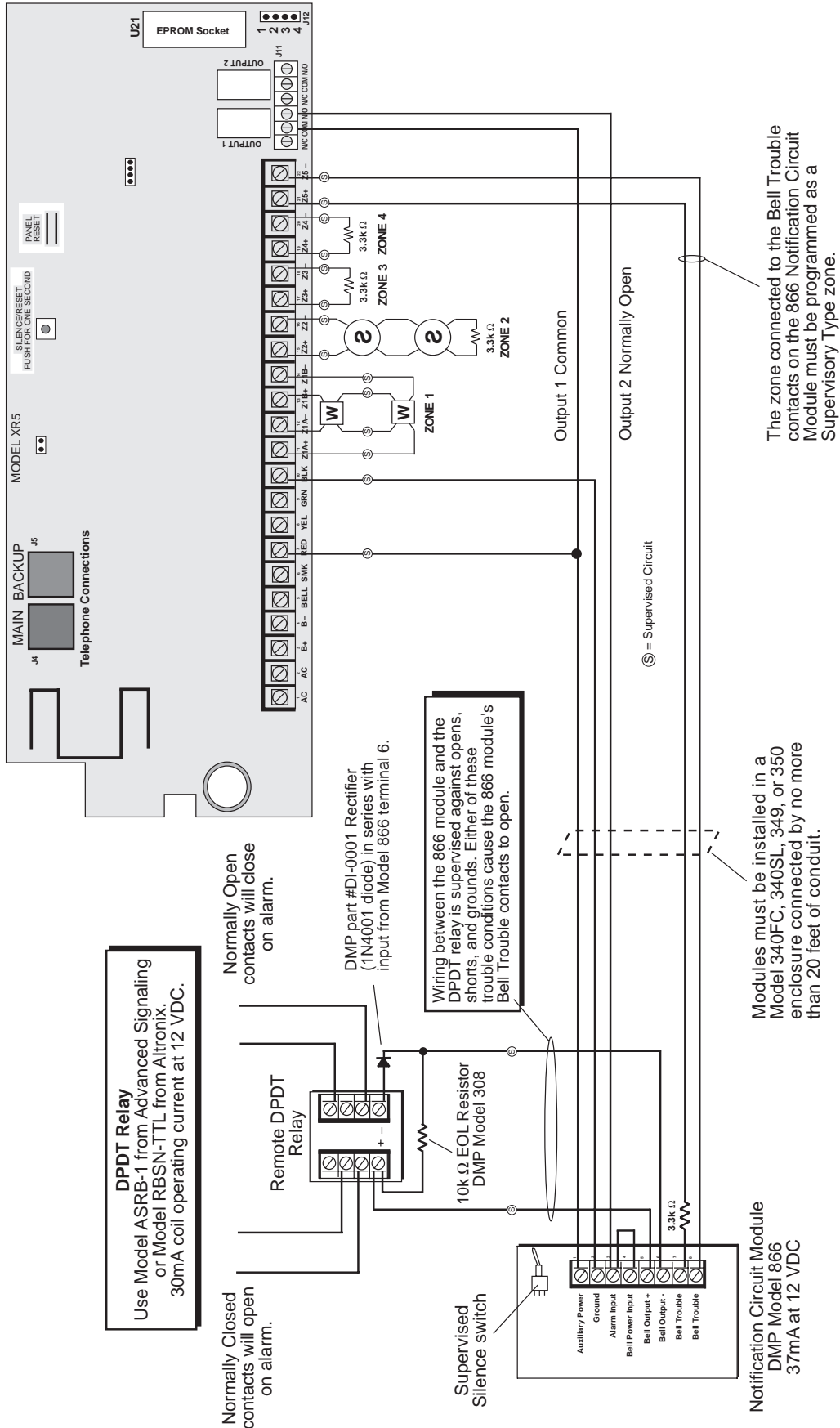

21.6 XR5SL Connection to FACP

AC Mode Wiring

When the XR5SL is used in the AC mode, the DMP Model 320 Transformer must be connected to the same branch circuit as the FACP. An AC power fail can then be delayed 6 to 12 hours by the XR5SL programming. See section 5.4 of the XR5SL Programming Guide (LT-0312). The FACP must not indicate AC fail to the XR5SL. Use Fire-Lite Models MS9200 or MS5012.

DC Mode Wiring

When the XR5SL is used in the DC mode, the FACP must indicate AC power fail on an independent relay output. This output must delay the AC power fail 6 to 12 hours. Use EST Model IRC-3 or Federal Signal 3000, 5000, or 5000E.

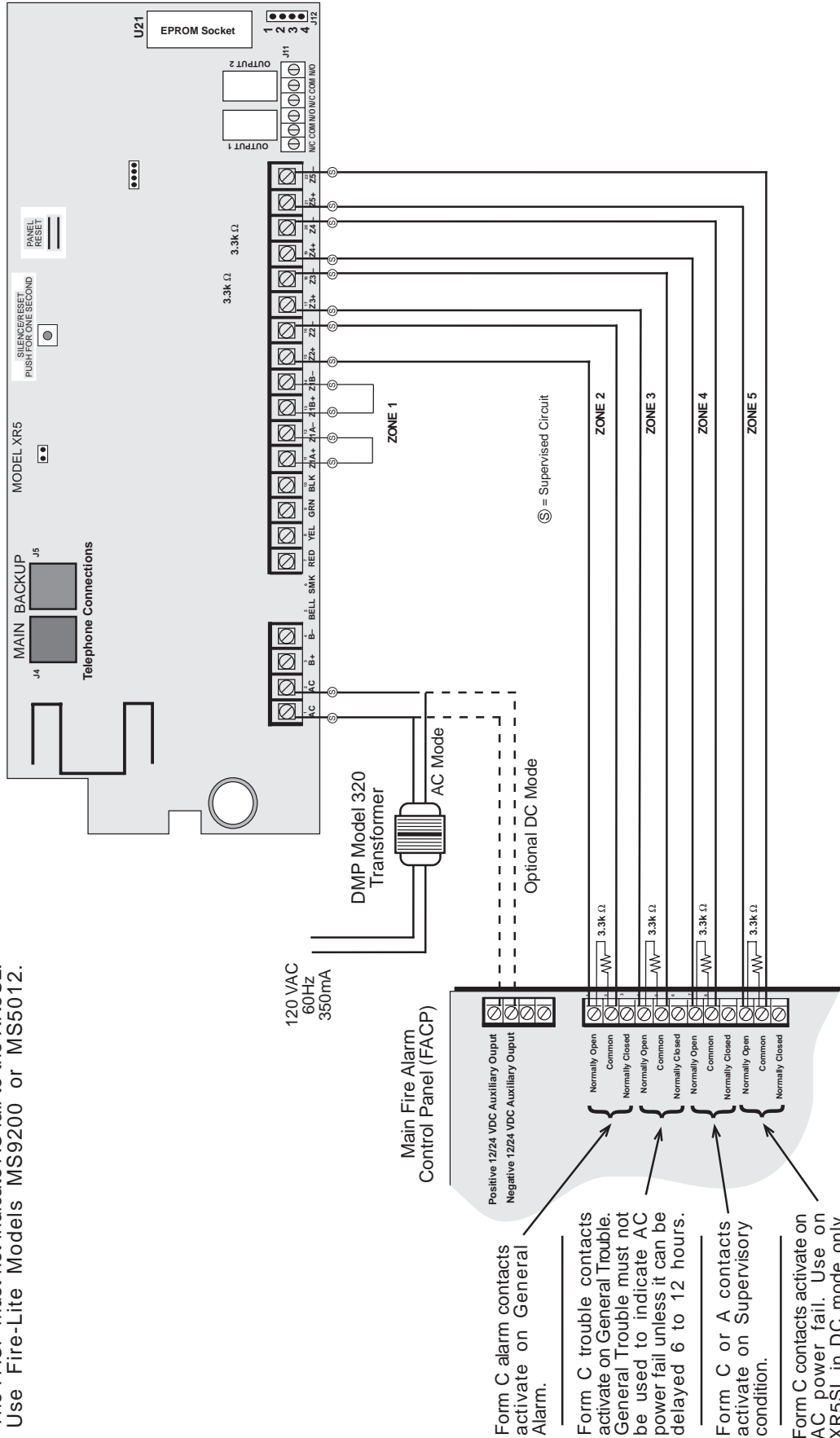

Form C alarm contacts activate on General Alarm.

Form C trouble contacts activate on General Trouble. General Trouble must not be used to indicate AC power fail unless it can be delayed 6 to 12 hours.

Form C or A contacts activate on Supervisory condition.

Form C contacts activate on AC power fail. Use on XR5SL in DC mode only. Must delay AC power fail 6 to 12 hours.